

Triton[®] T500

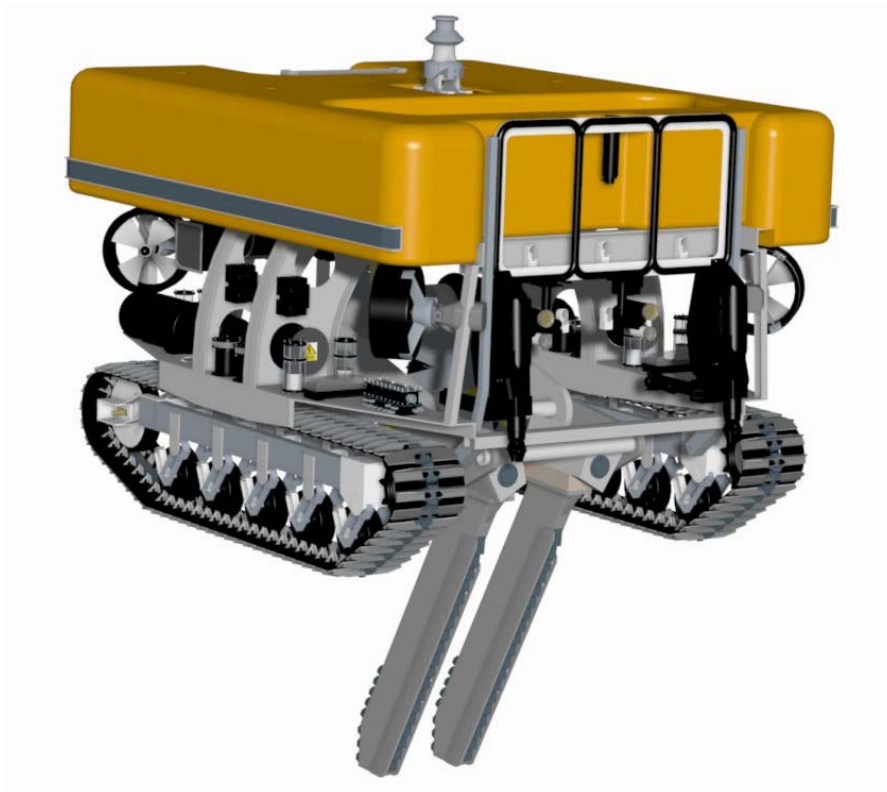

Cable and Pipe Burial ROV

■ Depth Rating	2500 MSW
■ Power	500 HP
■ Control System	Single Mode Fibre Optic PC Based
■ Burial Performance	Up to 3.0 m Burial 1 m @ 75 + Kpa
■ Pressure & Flow Water Jetting System	Variable
■ Lift Point	Variable
■ Soil Erosion System	



PERRY SLINGSBY SYSTEMS, LTD.

A MEMBER OF THE TRITON GROUP

www.perryslingsbysystems.com

Specifications		
Depth Capacity	2000 MSW (Deeper options on request)	
Thruster Configuration	-Four horizontal thrusters in quad arrangement -Three vertical thrusters	
Maximum Speed (Free flying)	Forward: 1.5 knots Lateral: 1.0 knots	
Maximum Speed (Tracked)	Forward: 1.0 knots	
Dimensions (Free flying)	Width (excluding tracks): 3930 mm Length: 4560 mm Height: 3400 mm	
Vehicle Weight	Free Fly Configuration: 11900 kg Tracked Mode Configuration: 11800 kg	
Propulsion System	- 100 HP Electrohydraulic power units (1) - Horizontal thrusters (4) - Vertical thrusters (3)	
Hydraulic Manifolds	- ROV, Thruster control manifold (Servo Valves) (1) - ROV, 10 function solenoid valve manifolds (2) - Trenching systems, 3 function, high flow proportional valve manifold (55 lpm per station) for track and pipe roller control (1)	
Lighting System (3000 watts total)	-250 watt lights, 2 per dimming circuit standard (12) -500 watt lights, 1 per dimming circuit optional (6)	
Depth Sensor	-High accuracy sensor, 0.1% over full scale for depth control (auto depth) and depth determination	
Heading Control	+2° Automatic or manual	
Depth Control	±150mm Automatic or manual	
Altitude Control	±150mm Automatic or manual	
Control System	-ROV Surface control-Pentium PC based, database driven software and real-time operating system -ROV subsea control-Pentium PC based, 32 bit STD bus	
		Spare Data Transmission -Real-time video channels available (8) -Spare fibre optic interface card slot (1) -Customer solenoid valve drivers (pre-wired) (9) -Customer digital out (8) -Customer digital in (8) -Customer analog out (4) -Customer analog in (8) -Full duplex RS232 @ 115 kbps data channels (4) -Full/half duplex RS485/422/232 @ 115 kbps channels (4) -Optional cable burial "Bagpipe" arms (various depth option) (2)
		Jetting System -100 HP direct drivewater pump (4) -4200 GPM max flow -140 psi max pressure - Front or rear mounted eductive pipeline burial tool -Front mounted "bagpipe" cable burial tool and cable depressor option
		Pipeline Burial Capabilities -Pipe Size Range – 150 to 400mm (diameter). Options available to 600mm -Cohesive Soil – Up to 30kPa -Non-Cohesive Soil – Sand, Silt and Gravel to 30mm -Burial Depth – 1.20m minimum to top of pipe -Burial Speed – Up to 1.0 knot
		Track System -Underwater Tracks, hydraulic driven (2) -Minimum Soil Strength – 3.5 kPa Shear Strength
		Optional Pipe Capture System -Pipe gripping rollers to provide motive force along pipeline during burial operations (2) -Front mounted guide roller (1) Both roller systems include raise/lower deployment mechanism to adjust ROV height off pipeline
		Additional Sensor and Tool Equipment -Scanning Sonar -Radio Beacon -Master/Slave or Rate Manipulators -Cable Cutter & Gripper Cable Location System -Navigation System -Dredge Pump -Strobe Flasher -Control/Work/Storage Vans -Umbilical Winch -Launch & Recovery System
Data Sheet: A001-350-052 Issue 3		

The specification details are illustrative for marketing purposes only. Actual equipment may be different as a result of product improvement or other reasons. Specific interface and performance information should be reconfirmed at time of order placement.

