

# Positive Compensation Unit

Perry Slingsby Systems offers a range of positive compensation units ranging from 0.48 litre to 1.75 litre. Larger volume, up to 33 litre, units are available to a different design style.

## Features

- Spring Actuated Rolling Diaphragm
- Available in a Range of Sizes
- Provides Positive Rate Compensation



480cc Compensation Unit

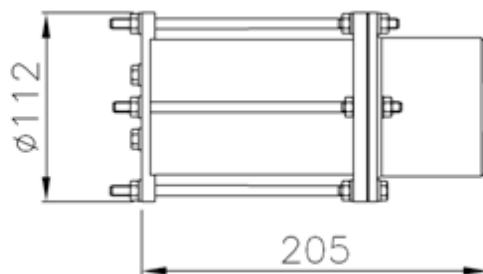

1.75L Compensation Unit

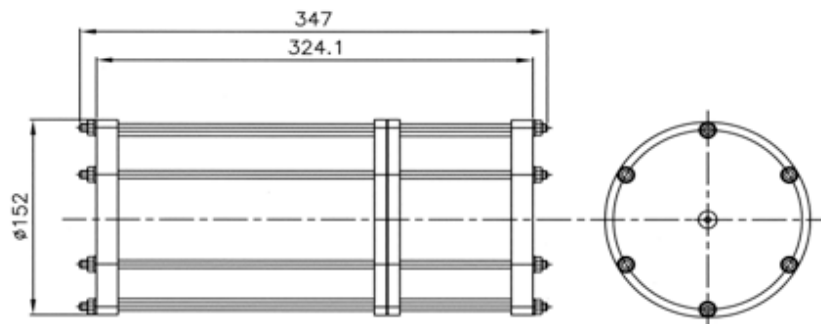

### 875cc Compensation Unit

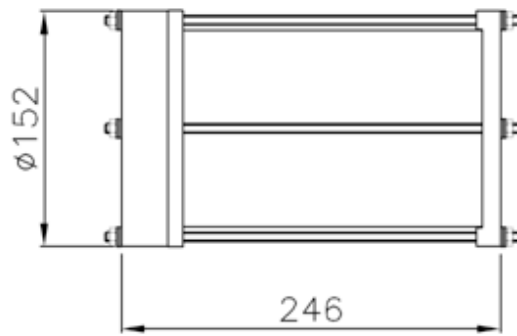

## Specification

Type:	Spring Actuated Rolling Diaphragm
Oil Capacity:	0.48, 0.875, or 1.75L
Positive Compensation:	0.3 Bar (5 psi) Max
Options	Integral Contents Level Sensor

Data Sheet: A001-350-017 Issue 5

The specification details are illustrative for marketing purposes only. Actual equipment may be different as a result of product improvement or other reasons. Specific interface and performance information should be reconfirmed at time of order placement.